



2017 catalog

For CO₂ and fiber laser consumables

Replacements parts suitable for Prima Industrie®



Our value proposition

- Product breadth – with over 2,800 part numbers
- OEM quality/consistency for nozzles, ceramics and optics
- Technical/application support from OEM-trained technicians
- 100% satisfaction guarantee



Consumables

	Centricut part number	Reference number	Alternate reference	Description	Pkg qty
1	PR331-4102	490.76.102	L70	Nozzle - 0.3 mm brass cylindrical	1
	PR331-4102X	490.76.102	L3070	Nozzle - 0.3 mm brass cylindrical (10 pack)	10
	PR331-0001B		L74	Nozzle - 1.0 mm brass cylindrical	1
	PR331-0001BX		L3074	Nozzle - 1.0 mm brass cylindrical (10 pack)	10
	PR331-0001		L418	Nozzle - 1.0 mm cylindrical	1
	PR331-0001X		L30418	Nozzle - 1.0 mm cylindrical (10 pack)	10
	PR331-0002		L416	Nozzle - 1.2 mm cylindrical	1
	PR331-0002X		L30416	Nozzle - 1.2 mm cylindrical (10 pack)	10
	PR331-3321B	485.73.321	L54	Nozzle - 1.5 mm brass cylindrical	1
	PR331-3321BX	485.73.321	L3054	Nozzle - 1.5 mm brass cylindrical (10 pack)	10
	PR331-3321C		L419	Nozzle - 1.5 mm cylindrical	1
	PR331-3321CX		L30419	Nozzle - 1.5 mm cylindrical (10 pack)	10
	PR331-0003		L417	Nozzle - 1.7 mm cylindrical	1
	PR331-0003X		L30417	Nozzle - 1.7 mm cylindrical (10 pack)	10
	PR331-3322B	485.73.322	L55	Nozzle - 2.0 mm brass cylindrical	1
	PR331-3322BX	485.73.322	L3055	Nozzle - 2.0 mm brass cylindrical (10 pack)	10
	PR331-322C		L420	Nozzle - 2.0 mm cylindrical	1
	PR331-322CX		L30420	Nozzle - 2.0 mm cylindrical (10 pack)	10
	PR331-3323B	485.73.323	L204	Nozzle - 2.5 mm brass cylindrical	1
	PR331-3323BX	485.73.323	L30204	Nozzle - 2.5 mm brass cylindrical (10 pack)	10
	PR331-3323C		L421	Nozzle - 2.5 mm cylindrical	1
	PR331-3323CX		L30421	Nozzle - 2.5 mm cylindrical (10 pack)	10
	PR331-3324B	485.73.324	L205	Nozzle - 3.0 mm brass cylindrical	1
	PR331-3324BX	485.73.324	L30205	Nozzle - 3.0 mm brass cylindrical (10 pack)	10
	PR331-3324		L422	Nozzle - 3.0 mm cylindrical	1
	PR331-3324X		L30422	Nozzle - 3.0 mm cylindrical (10 pack)	10
	PR331-0001CP		L418X	Nozzle - 1.0 mm CP	1
	PR331-0001CPX		L30418X	Nozzle - 1.0 mm CP (10 pack)	10
	PR331-0002CP		L416X	Nozzle - 1.2 mm CP	1
	PR331-0002CPX		L30416X	Nozzle - 1.2 mm CP (10 pack)	10
	PR331-0321CCP	485.73.421	L419X	Nozzle - 1.5 mm CP	1
	PR331-0321CCPX	485.73.421	L30419X	Nozzle - 1.5 mm CP (10 pack)	10
	PR331-0003CP		L417X	Nozzle - 1.7 mm CP	1
	PR331-0003CPX		L30417X	Nozzle - 1.7 mm CP (10 pack)	10
	PR331-322CCP	485.73.422	L420X	Nozzle - 2.0 mm CP	1
	PR331-322CCPX	485.73.422	L30420X	Nozzle - 2.0 mm CP (10 pack)	10
	PR331-3323CCP	485.73.423	L421X	Nozzle - 2.5 mm CP	1
	PR331-3323CCPX	485.73.423	L30421X	Nozzle - 2.5 mm CP (10 pack)	10
	PR331-3324CP	485.73.424	L422X	Nozzle - 3.0 mm CP	1
	PR331-3324CPX	485.73.424	L30422X	Nozzle - 3.0 mm CP (10 pack)	10
2	PR331-0301	490.1N.301	L1245	Nozzle - 2.0 mm brass short	1
	PR331-0301X	490.1N.301	L301245	Nozzle - 2.0 mm brass short (10 pack)	10
	PR331-0302	490.1N.302	L1246	Nozzle - 2.5 mm brass short	1
	PR331-0302X	490.1N.302	L301246	Nozzle - 2.5 mm brass short (10 pack)	10



Consumables

	Centricut part number	Reference number	Alternate reference	Description	Pkg qty
1	PR393-0001		L631	Nozzle - 0.3 mm	1
	PR393-0001X		L30631	Nozzle - 0.3 mm (10 pack)	10
	PR393-0002		L632	Nozzle - 1.0 mm	1
	PR393-0002X		L30632	Nozzle - 1.0 mm (10 pack)	10
	PR393-0003		L637	Nozzle - 1.2 mm	1
	PR393-0003X		L30637	Nozzle - 1.2 mm (10 pack)	10
	PR393-0004		L633	Nozzle - 1.5 mm	1
	PR393-0004X		L30633	Nozzle - 1.5 mm (10 pack)	10
	PR398-0005		L638	Nozzle - 1.7 mm	1
	PR398-0005X		L30638	Nozzle - 1.7 mm (10 pack)	10
	PR393-0006		L634	Nozzle - 2.0 mm	1
	PR393-0006X		L30634	Nozzle - 2.0 mm (10 pack)	10
	PR393-0007		L635	Nozzle - 2.5 mm	1
	PR393-0007X		L30635	Nozzle - 2.5 mm (10 pack)	10
	PR393-0008		L636	Nozzle - 3.0 mm	1
	PR393-0008X		L30636	Nozzle - 3.0 mm (10 pack)	10
2	PR393-3455CP	485.73.455	L1231X	Nozzle - 0.3 mm CP	1
	PR393-3455X		L301231	Nozzle - 0.3 mm (10 pack)	10
	PR393-3455CPX	485.73.455	L301231X	Nozzle - 0.3 mm CP (10 pack)	10
	PR393-3451CP	485.73.451	L1235X	Nozzle - 1.5 mm CP	1
	PR393-3451X		L301235	Nozzle - 1.5 mm (10 pack)	10
	PR393-3451CPX	485.73.451	L301235X	Nozzle - 1.5 mm CP (10 pack)	10
	PR393-3452CP	485.73.452	L1236X	Nozzle - 2.0 mm CP	1
	PR393-3452X		L301236	Nozzle - 2.0 mm (10 pack)	10
	PR393-3452CPX	485.73.452	L301236X	Nozzle - 2.0 mm CP (10 pack)	10
	PR393-3453CP	485.73.453	L1237X	Nozzle - 2.5 mm CP	1
	PR393-3453X		L301237	Nozzle - 2.5 mm (10 pack)	10
	PR393-3453CPX	485.73.453	L301237X	Nozzle - 2.5 mm CP (10 pack)	10

Centricut is not affiliated with the named manufacturers. Reference to machines, parts, descriptions, and model numbers are for convenience in verifying compatibility only. All parts are made by or for Centricut and are not made by the referenced manufacturers (unless expressly indicated). Centricut is a registered trademark of Hypertherm, Inc. All other trademarks are the properties of their respective owners.

Consumables

	Centricut part number	Reference number	Alternate reference	Description	Pkg qty
1	PR357-0001	490.76.103	L62	Nozzle - 0.3 mm conical brass	1
	PR357-0001X	490.76.103	L3062	Nozzle - 0.3 mm conical brass (10 pack)	10
	PR357-0002		L450	Nozzle - 1.0 mm conical	1
	PR357-0002X		L30450	Nozzle - 1.0 mm conical (10 pack)	10
	PR357-0003		L451	Nozzle - 1.2 mm conical	1
	PR357-0003X		L30451	Nozzle - 1.2 mm conical (10 pack)	10
	PR357-331B	485.73.331	L206	Nozzle - 1.5 mm conical brass	1
	PR357-331BX	485.73.331	L30206	Nozzle - 1.5 mm conical brass (10 pack)	10
	PR357-331C		L424	Nozzle - 1.5 mm conical	1
	PR357-331CX		L30424	Nozzle - 1.5 mm conical (10 pack)	10
	PR357-0004		L426	Nozzle - 1.7 mm conical	1
	PR357-0004X		L30426	Nozzle - 1.7 mm conical (10 pack)	10
	PR357-333B	485.73.333	L57	Nozzle - 2.0 mm conical brass	1
	PR357-333BX	485.73.333	L3057	Nozzle - 2.0 mm conical brass (10 pack)	10
	PR357-333C		L425	Nozzle - 2.0 mm conical	1
	PR357-333CX		L30425	Nozzle - 2.0 mm conical (10 pack)	10
	PR357-0005	485.73.333	L449	Nozzle - 2.5 mm conical brass	1
	PR357-0005X	485.73.333	L30449	Nozzle - 2.5 mm conical brass (10 pack)	10
	PR357-0006		L427	Nozzle - 2.5 mm conical	1
	PR357-0006X		L30427	Nozzle - 2.5 mm conical (10 pack)	10
	PR357-0007		L630	Nozzle - 3.0 mm conical	1
	PR357-0007X		L30630	Nozzle - 3.0 mm conical (10 pack)	10
	PR357-0002CP		L450X	Nozzle - 1.0 mm CP	1
	PR357-0002CPX		L30450X	Nozzle - 1.0 mm CP (10 pack)	10
	PR357-0003CP		L451X	Nozzle - 1.2 mm CP	1
	PR357-0003CPX		L30451X	Nozzle - 1.2 mm CP (10 pack)	10
	PR357-331CCP	485.73.431	L424X	Nozzle - 1.5 mm CP	1
	PR357-331CCPX	485.73.431	L30424X	Nozzle - 1.5 mm CP (10 pack)	10
	PR357-0004CP		L426X	Nozzle - 1.7 mm CP	1
	PR357-0004CPX		L30426X	Nozzle - 1.7 mm CP (10 pack)	10
	PR357-322CCP	485.73.433	L425X	Nozzle - 2.0 mm CP	1
	PR357-322CCPX	485.73.433	L30425X	Nozzle - 2.0 mm CP (10 pack)	10
	PR357-0006CP		L427X	Nozzle - 2.5 mm CP	1
	PR357-0006CPX		L30427X	Nozzle - 2.5 mm CP (10 pack)	10
PR357-0007CP	485.73.43x	L630X	Nozzle - 3.0 mm CP	1	
PR357-0007CPX	485.73.43x	L30630X	Nozzle - 3.0 mm CP (10 pack)	10	
2	PR395-0001	480.73.107	AL136	Insulating ring 5" (plastic)	1
	PR395-0002		AL163	Insulating ring 7.5" (plastic)	1

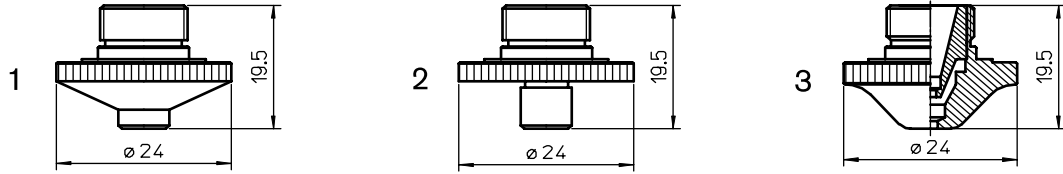

Consumables

	Centricut part number	Reference number	Alternate reference	Description	Pkg qty
1	PR351-1E109		L532	Nozzle - 0.8 mm	1
	PR351-1E110		L312	Nozzle - 1.0 mm	1
	PR351-1E108		L362	Nozzle - 1.2 mm	1
	PR351-1E111	LW6.1E.111	L207	Nozzle - 1.5 mm	1
	PR351-1E112	LW6.1E.112	L208	Nozzle - 2.0 mm	1
	PR351-1E113	LW6.1E.113	L209	Nozzle - 2.5 mm	1
	PR351-1E114	LW6.1E.114	L210	Nozzle - 3.0 mm	1
	PR351-1E110CP		L312X	Nozzle - 1.0 mm CP	1
	PR351-1E115CP		L362X	Nozzle - 1.2 mm CP	1
	PR351-1E111CP	LW6.1E.111	L207X	Nozzle - 1.5 mm CP	1
	PR351-1E112CP	LW6.1E.112	L208X	Nozzle - 2.0 mm CP	1
	PR351-1E113CP	LW6.1E.113	L209X	Nozzle - 2.5 mm CP	1
	PR351-1E114CP	LW6.1E.114	L210X	Nozzle - 3.0 mm CP	1
	2	PR366-1G600	LW6.1G.500, LW6.1G.600	L608	Nozzle - 1.5 mm
PR366-1G601		LW6.1G.501, LW6.1G.601	L609	Nozzle - 2.0 mm	1
PR366-1G602		LW6.1G.502, LW6.1G.602	L610	Nozzle - 2.5 mm	1
PR366-1G603		LW6.1G.503, LW6.1G.603	L611	Nozzle - 3.0 mm	1
PR366-1G601CP		LW6.1G.501, LW6.1G.601	L609X	Nozzle - 2.0 mm CP	1
PR366-1G602CP		LW6.1G.502, LW6.1G.602	L610X	Nozzle - 2.5 mm CP	1
PR366-1G603CP		LW6.1G.503, LW6.1G.603	L611X	Nozzle - 3.0 mm CP	1
3		PR362-0008CP	1059.70000.010	L905X	Nozzle - 0.8 mm double CP
	PR362-0003CP	1059.70000.003	L900X	Nozzle - 1.0 mm double CP	1
	PR362-0002CP	1059.70000.008	L907X	Nozzle - 1.25 mm double CP	1
	PR362-0005CP	1059.70000.004	L901X	Nozzle - 1.5 mm double CP	1
	PR362-0001CP	1059.70000.009	L906X	Nozzle - 1.75 mm double CP	1
	PR362-0004CP	1059.70000.005	L902X	Nozzle - 2.0 mm double CP	1
	PR362-0006CP	1059.70000.006	L903X	Nozzle - 2.5 mm double CP	1
	PR362-0007CP	1059.70000.007	L904X	Nozzle - 3.0 mm double CP	1

Centricut is not affiliated with the named manufacturers. Reference to machines, parts, descriptions, and model numbers are for convenience in verifying compatibility only. All parts are made by or for Centricut and are not made by the referenced manufacturers (unless expressly indicated). Centricut is a registered trademark of Hypertherm, Inc. All other trademarks are the properties of their respective owners.

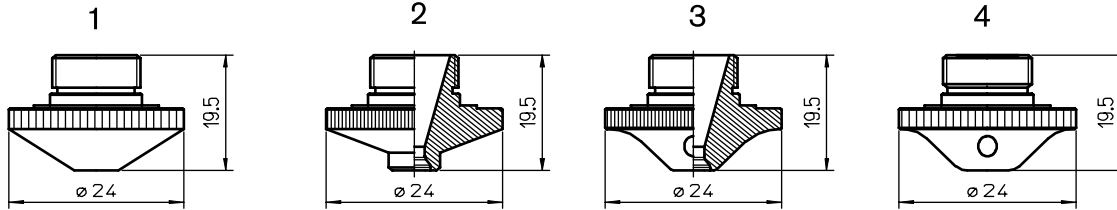

Consumables

	Centricut part number	Reference number	Alternate reference	Description	Pkg qty
1	PR422-0001	Centricut design	L862	Nozzle - 1.0 mm	1
	PR422-0002	Centricut design	L863	Nozzle - 1.5 mm	1
	PR422-0003	Centricut design	L864	Nozzle - 2.0 mm	1
	PR422-0004	Centricut design	L865	Nozzle - 2.5 mm	1
	PR422-0005	Centricut design	L866	Nozzle - 3.0 mm	1
2	PR422-0650CP	LW6.1G.650	L1165X	Nozzle - 3.0 mm CP	1
3	PR422-0608CP	LW6.1G.608	L1208X	Nozzle - 3.0 mm CP	1
	PR422-0609CP	LW6.1G.609	L1209X	Nozzle - 3.5 mm CP	1
4	PR394-604	LW6.1G.604	L1167X	Nozzle - 1.5 mm CP	1
	PR394-603		L1166X	Nozzle - 1.75 mm CP	1
	PR394-605	LW6.1G.605	L1168X	Nozzle - 2.0 mm CP	1
	PR394-606	LW6.1G.606	L1169X	Nozzle - 2.5 mm CP	1
	PR394-607	LW6.1G.607	L1170X	Nozzle - 3.0 mm CP	1

Sensor cables

	Centricut part number	Reference number	Alternate reference	Description	Pkg qty
1	PR361-3150 (not shown)	820.63.150		Sensor cable - 150 mm	1

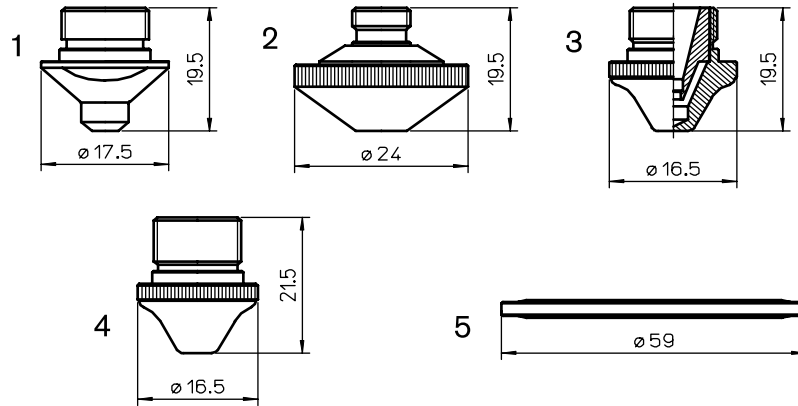
Consumables

	Centricut part number	Reference number	Alternate reference	Description	Pkg qty
1	PR398-498	750.42.559	L922	Nozzle - 0.3 mm	1
	PR398-0001		L891	Nozzle - 1.0 mm	1
	PR398-550	750.42.550	L892	Nozzle - 1.5 mm	1
	PR398-551	750.42.551	L893	Nozzle - 2.0 mm	1
	PR398-552	750.42.552	L894	Nozzle - 2.5 mm	1
	PR398-0004	750.42.553	L895	Nozzle - 3.0 mm	1
	PR398-0001CP		L891X	Nozzle - 1.0 mm CP	1
	PR398-0006	750.42.550	L892X	Nozzle - 1.5 mm CP	1
	PR398-0002CP	750.42.551	L893X	Nozzle - 2.0 mm CP	1
	PR398-0003CP	750.42.552	L894X	Nozzle - 2.5 mm CP	1
	PR398-0004CP	750.42.553	L895X	Nozzle - 3.0 mm CP	1
2	PR399-0001		L875	Nozzle - 1.0 mm	1
	PR399-0002		L876	Nozzle - 1.5 mm	1
	PR399-0003	LW3.1E.102	L877	Nozzle - 2.0 mm	1
	PR399-0004	LW3.1E.103	L878	Nozzle - 2.5 mm	1
	PR399-0005	LW3.1E.104	L879	Nozzle - 3.0 mm	1
3	PR421-111CP	520.17.111	L1239X	Nozzle - 1.5 mm double CP	1
	PR421-114CP	520.17.114	L1240X	Nozzle - 2.0 mm double CP	1
	PR421-560CP	750.43.560	L1241X	Nozzle - 2.5 mm double CP	1
	PR421-561CP	750.43.561	L1242X	Nozzle - 3.0 mm double CP	1
	PR421-562CP	750.43.562	L1243X	Nozzle - 3.5 mm double CP	1
4	PR409-4515	787.04.515	L1211X	Nozzle - 1.25 mm CP	1
	PR409-4512	787.04.512	L1212X	Nozzle - 1.5 mm CP	1
	PR409-4516	787.04.516	L1217X	Nozzle - 1.75 mm CP	1
	PR409-4513	787.04.513	L1213X	Nozzle - 2.0 mm CP	1
	PR409-4514	787.04.514	L1214X	Nozzle - 2.5 mm CP	1
5	PR421-720	1058.36520.720	AL259	Lens gasket	1

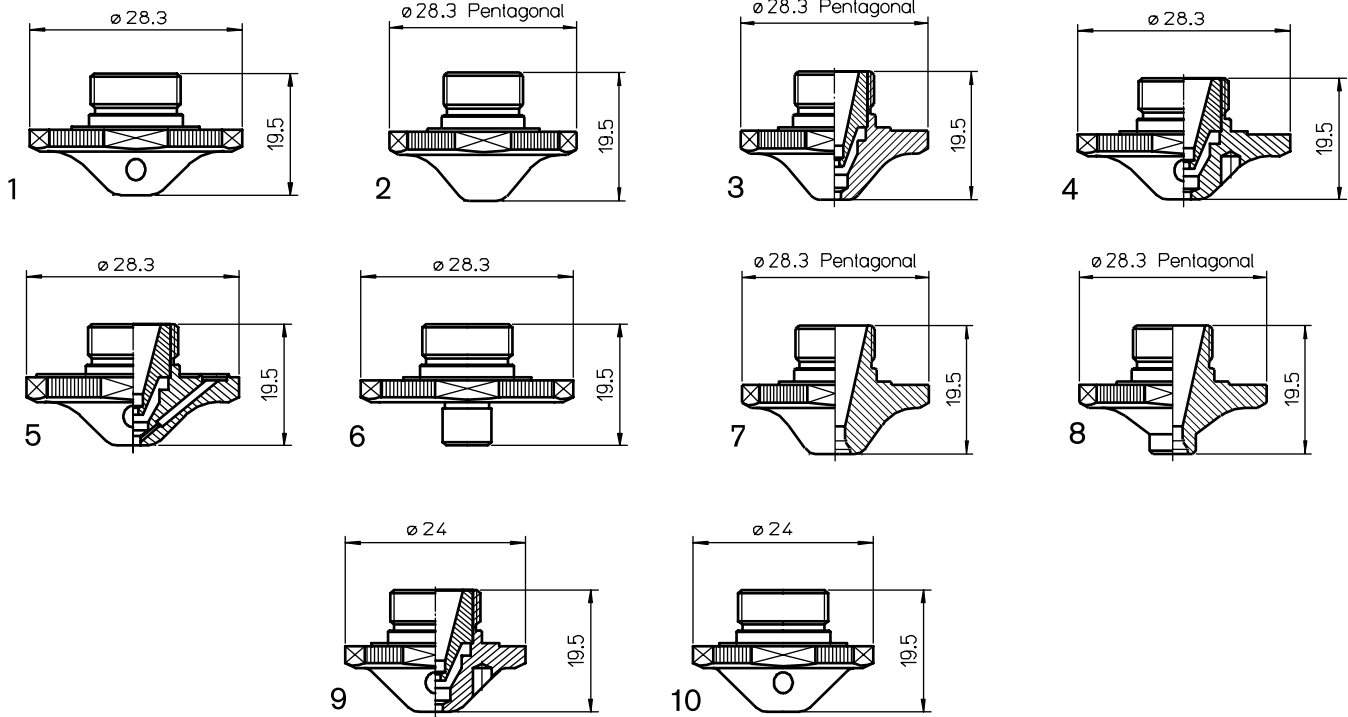

Consumables

	Centricut part number	Reference number	Alternate reference	Description	Pkg qty
1	PR422-0660	LW6.1G.660	L1428X	Nozzle pentagonal 0.8 mm CP	1
	PR422-0661	LW6.1G.661	L1429X	Nozzle pentagonal 1.0 mm CP	1
	PR422-0662	LW6.1G.662	L1430X	Nozzle pentagonal 1.25 mm CP	1
	PR422-0663	LW6.1G.663	L1431X	Nozzle pentagonal 1.5 mm CP	1
	PR422-0664	LW6.1G.664	L1432X	Nozzle pentagonal 1.75 mm CP	1
	PR422-0665	LW6.1G.665	L1433X	Nozzle pentagonal 2.0 mm CP	1
	PR422-0666	LW6.1G.666	L1434X	Nozzle pentagonal 2.25 mm CP	1
	PR422-0667	LW6.1G.667	L1435X	Nozzle pentagonal 2.5 mm CP	1
	PR422-0668	LW6.1G.668	L1436X	Nozzle pentagonal 2.75 mm CP	1
	PR422-0669	LW6.1G.669	L1437X	Nozzle pentagonal 3.0 mm CP	1
PR422-0670	LW6.1G.670	L1438X	Nozzle pentagonal 3.5 mm CP	1	
2	PR422-0103CP NEW	LW6.1G.103	L1807X	Nozzle pentagonal 1.5 mm CP	1
	PR422-0105CP NEW	LW6.1G.105	L1808X	Nozzle pentagonal 2.0 mm CP	1
	PR422-0107CP NEW	LW6.1G.107	L1809X	Nozzle pentagonal 2.5 mm CP	1
	PR422-0109CP NEW	LW6.1G.109	L1810X	Nozzle pentagonal 3.0 mm CP	1
3	PR422-1462 NEW		L1462	Double nozzle pentagonal 3.0 mm	1
	PR422-1463 NEW		L1463	Double nozzle pentagonal 3.5 mm	1
	PR422-1464 NEW		L1464	Double nozzle pentagonal 4.0 mm	1
	PR422-1472 NEW		L1472	Double nozzle pentagonal 5.0 mm	1
	PR422-1473 NEW		L1473	Double nozzle pentagonal 7.0 mm	1
	PR422-1783CP NEW		L1783X	Double nozzle pentagonal 1.25 mm CP	1
	PR422-1784CP NEW		L1784X	Double nozzle pentagonal 1.5 mm CP	1
	PR422-1785CP NEW		L1785X	Double nozzle pentagonal 1.75 mm CP	1
	PR422-1786CP NEW		L1786X	Double nozzle pentagonal 2.0 mm CP	1
	PR422-1787CP NEW		L1787X	Double nozzle pentagonal 2.5 mm CP	1
	PR422-1788CP NEW		L1788X	Double nozzle pentagonal 2.5 mm-2.0 mm CP	1
	PR422-1789CP NEW		L1789X	Double nozzle pentagonal 3.0 mm CP	1
	PR422-1790CP NEW		L1790X	Double nozzle pentagonal 3.0 mm-2.0 mm CP	1
	PR422-1791CP NEW		L1791X	Double nozzle pentagonal 3.5 mm-3.0 mm CP	1

Centricut is not affiliated with the named manufacturers. Reference to machines, parts, descriptions, and model numbers are for convenience in verifying compatibility only. All parts are made by or for Centricut and are not made by the referenced manufacturers (unless expressly indicated). Centricut is a registered trademark of Hypertherm, Inc. All other trademarks are the properties of their respective owners.

Consumables

	Centricut part number	Reference number	Alternate reference	Description	Pkg qty
4	PR422-0680	LW6.1G.680	L1440X	Double nozzle pentagonal 0.8 mm CP	1
	PR422-0681	LW6.1G.681	L1441X	Double nozzle pentagonal 1.0 mm CP	1
	PR422-0682	LW6.1G.682	L1442X	Double nozzle pentagonal 1.25 mm CP	1
	PR422-0683	LW6.1G.683	L1443X	Double nozzle pentagonal 1.5 mm CP	1
	PR422-0684	LW6.1G.684	L1444X	Double nozzle pentagonal 1.75 mm CP	1
	PR422-0685	LW6.1G.685	L1445X	Double nozzle pentagonal 2.0 mm CP	1
	PR422-0686	LW6.1G.686	L1446X	Double nozzle pentagonal 2.25 mm CP	1
	PR422-0687	LW6.1G.687	L1447X	Double nozzle pentagonal 2.5 mm CP	1
	PR422-0688	LW6.1G.688	L1448X	Double nozzle pentagonal 2.75 mm CP	1
	PR422-0689	LW6.1G.689	L1449X	Double nozzle pentagonal 3.0 mm CP	1
	PR422-0800	LW6.1G.800	L1465	Double nozzle brilliant 3.0 mm	1
	PR422-0801	LW6.1G.801	L1466	Double nozzle brilliant 3.5 mm	1
	PR422-0802	LW6.1G.802	L1467	Double nozzle brilliant 4.0 mm	1
	PR422-0803	LW6.1G.803	L1468	Double nozzle brilliant 5.0 mm	1
PR422-0804	LW6.1G.804	L1469	Double nozzle brilliant 7.0 mm	1	
5	PR422-0627	LW6.1G.627	L1453X	Triple nozzle pentagonal 1.25 mm CP	1
	PR422-0620	LW6.1G.620	L1454X	Triple nozzle pentagonal 1.5 mm CP	1
	PR422-0621	LW6.1G.621	L1455X	Triple nozzle pentagonal 1.75 mm CP	1
	PR422-0622	LW6.1G.622	L1456X	Triple nozzle pentagonal 2.0 mm CP	1
	PR422-0623	LW6.1G.623	L1457X	Triple nozzle pentagonal 2.25 mm CP	1
	PR422-0624	LW6.1G.624	L1458X	Triple nozzle pentagonal 2.5 mm CP	1
	PR422-0625	LW6.1G.625	L1459X	Triple nozzle pentagonal 2.75 mm CP	1
PR422-0626	LW6.1G.626	L1460X	Triple nozzle pentagonal 3.0 mm CP	1	
6	PR422-0699	LW6.1G.699	L1477X	Nozzle pentagonal 1.5 mm CP (CYL)	1
	PR422-0700	LW6.1G.700	L1478X	Nozzle pentagonal 2.0 mm CP (CYL)	1
	PR422-0701	LW6.1G.701	L1479X	Nozzle pentagonal 2.5 mm CP (CYL)	1
	PR422-0702	LW6.1G.702	L1480X	Nozzle pentagonal 3.0 mm CP (CYL)	1
7	PR422-0522CP NEW	LW6.1G.522a	L1837X	Nozzle pentagonal 4.5 mm DL CP	1
8	PR422-0524CP NEW	LW6.1G.524	L1838X	Nozzle pentagonal 3.0 mm DL CP	1
9	PR422-0643	LW6.1G.643	L1540X	Double nozzle pentagonal 1.5 mm CP	1
	PR422-0645	LW6.1G.645	L1541X	Double nozzle pentagonal 2.0 mm CP	1
	PR422-0647	LW6.1G.647	L1542X	Double nozzle pentagonal 2.5 mm CP	1
10	PR422-0633	LW6.1G.633	L1533X	Nozzle pentagonal 1.5 mm CP	1
	PR422-0635	LW6.1G.635	L1534X	Nozzle pentagonal 2.0 mm CP	1
	PR422-0637	LW6.1G.637	L1535X	Nozzle pentagonal 2.5 mm CP	1

Optics

Centricut part number	Reference number	Type	Diameter	Focal length	Edge thickness
Lenses					
PR361-9002	834-319-002	PLX	1.5"	5.0"	.236"
PR361-0773	970773	PLX	1.5"	5.0"	.275"
PR361-9011	834-319-011	PLX	1.5"	5.0"	.300"
PR361-8988NM		PLX	1.5"	5.0"	.275"
PR361-0003	834-319-003	PLX	1.5"	7.5"	.236"
PR361-9012	834-319-012	PLX	1.5"	7.5"	.300"
PR361-0004	120216	MEN	1.5"	5.0"	.354"
PR361-0005	570721	MEN	1.5"	7.5"	.354"
PR361-0001	741363	PLX	2.0"	5.0"	.380"
PR361-0002	232771	PLX	2.0"	7.5"	.380"

Centricut part number	Reference number	Type	Material	Diameter	Focal length	Edge thickness
One micron optics						
PR361-2284	632284-17	PLX	FS	38.10 mm	190 mm	7.10 mm
PR361-4001	ESTFLO2066-1	MEN	FS	25 mm	8.6K mm	3.30 mm
PR361-4002	ESTFLO2066-2	BCX	FS	25 mm	267 mm	2.60 mm
PR361-8988	LH968988pvl	PLX	FS	38.1 mm	127 mm	1.92 mm

Centricut part number	Reference number	Type	Diameter	Edge thickness
One micron windows				
PR361-0474	970474	FS	37.0 mm	4.00 mm

Optics care

Centricut part number	Reference number	Description	Pkg qty
TR300-6452	N/A	Lens cleaning paper, Tiffen – 50 piece	1
AM313-SC50	SC50	Lens cleaning paper, Tresor – 50 piece	1
TR300-1115		Lens cleaning pre-cut cotton – 80 piece	1
TR300-SC20		Cotton swab – 20 piece	1
TR300-1010	AL1010	Dropper, lens cleaning fluid	1
TR300-1112		Optical cleaning fluid	1
TR300-0699	70675699 REVA	Lens Cleaning Swabs (25 pack)	1
TR300-7991	027991	Polyester Wipes 4" x 4"	1
TR301-0282		Injector	1
TR300-LSA		Lens stress analyzer	1
TR300-255	AL255	Loupe, magnifying	1
TR300-271	AL271	Base, lens maintenance	1
TR300-7388	787388	Mirror polish (250 ml)	1

Centricut is not affiliated with the named manufacturers. Reference to machines, parts, descriptions, and model numbers are for convenience in verifying compatibility only. All parts are made by or for Centricut and are not made by the referenced manufacturers (unless expressly indicated). Centricut is a registered trademark of Hypertherm, Inc. All other trademarks are the properties of their respective owners.

Technical support

- Our technical service team can answer questions about any laser or plasma cutting system. Whether it's a question about a part, a system, or for guidance on how to optimize performance, our experts can help.
- We stand behind our products with industry-leading technical expertise
- OEM trained technicians on staff with over 25 years experience



**HELPING YOU
SHAPE THE WORLD.**



PLASMA | LASER | WATERJET | AUTOMATION | SOFTWARE | CONSUMABLES

For more information on Centricut laser products, visit
www.hypertherm.com/centricut/laser

Hypertherm, Centricut, SilverLine and CoolFlow are trademarks of Hypertherm Inc., and may be registered in the United States and/or other countries. All other trademarks are the property of their respective owners.

One of Hypertherm's long-standing core values is a focus on minimizing our impact on the environment. Doing so is critical to our, and our customers' success. We are always striving to become better environmental stewards; it is a process we care deeply about.

© 12/2016 Hypertherm Inc.



Hypertherm[®]
SHAPING POSSIBILITY™

